

Medium Expansion Foam Branchpipe M2 - M4

Description

M2 and M4 branchpipes are designed for firefighting to apply a safety blanket of medium expanded foam. Medium expansion foams provide increased safety when applied during an intervention especially where flammable liquids are involved. Risks of re-ignition of flammable liquids are considerably reduced due to the height of foam blanket created.

The advantage of medium expansion foam compared to low expansion foam is that up to 5 times more foam can be produced with the same amount of water.

This reduces clean-up costs. It is also possible to fill a small room and to blanket flammable liquids as a preventive measure in the event of a nearby fire.

Application

M2 and M4 medium expansion foam branchpipes performs well with fluoroprotein, multipurpose, AFFF, FFFP, and ARC foam concentrates.

Typical applications for M2 and M4 branchpipes include the oil and chemical industries, general industry, airports, and fire brigades.

Features

M2 and M4 medium expansion foam branchpipes have the following features:

- High protection against corrosion
- Low weight equipment
- Available in 200 Lpm and 400 Lpm flows
- Pressure gauge to show water pressure at branchpipe
- Perform with all foams including AFFF-ARC

Construction

Construction in stainless steel, rubber, and plastic ensures optimum protection against corrosion. The nozzle, coupling, and shut-off valve are produced from light metal for easy handling.

M2 and M4 medium expansion branchpipes produce a high quality foam which meets the requirements of the German Standard (DIN).



Recommended Foam Concentrate

M2 and M4 medium expansion branchpipes perform with all types of foam concentrates, including alcohol resistant concentrates.

The foam concentrate used with M2 and M4 branchpipes should be of a suitable type for the risk to be protected, for example, ARC foam concentrates for water miscible liquid fires.

For more information or regarding specific guidelines, contact your local distributor or email info@skum.com

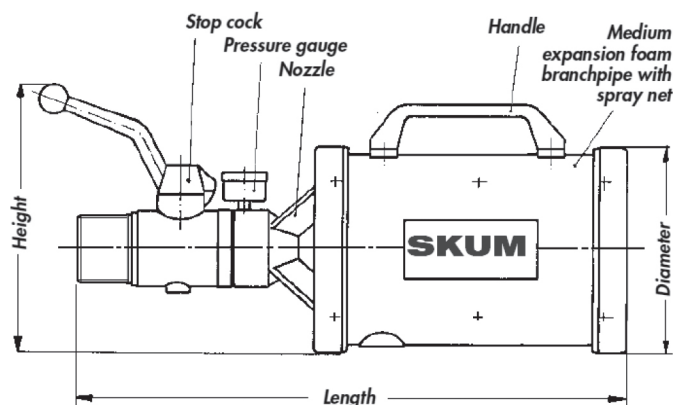

Specifications

	M2	M4
Water flow	200 Lpm	400 Lpm
Operating pressure	5 bar	
Expansion rate approx.	50	
Throw approx.	8 m	9 m
Qty of foam per minute approx.	10 m ³	20 m ³
Inlet Connection	2" (DN50) female BSP	
Length (with stop valve)	545 mm	630 mm
Max width	250 mm	305 mm
Weight	4.0 kg	5.2 kg

Performance

Pressure vs. Flow Rate

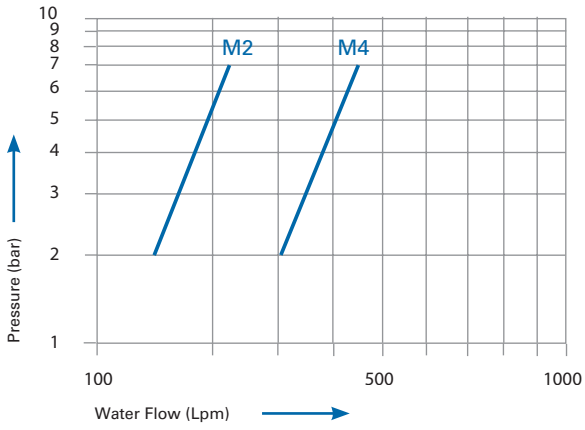

Pressure vs. Throw Range

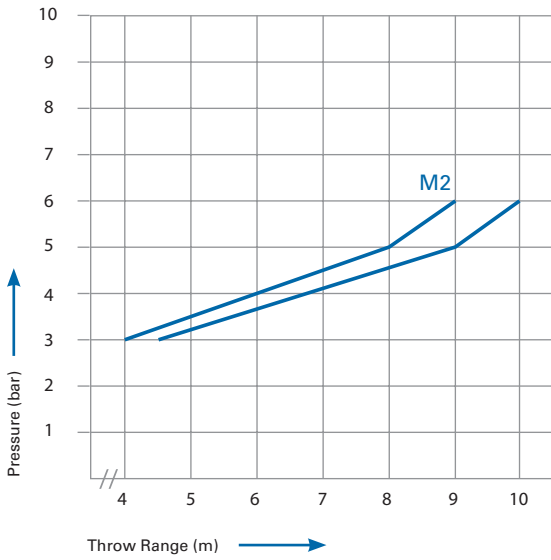

Ordering Information

When ordering, specify the following information:

Part No.	Description
101824164	M2 with stop valve
101824173	M2 without stop valve
101824169	M4 with stop valve
101824172	M4 without stop valve

Note: The converted values in this document are provided for dimensional reference only and do not reflect an actual measurement.

SKUM and the product names listed in this material are marks and/or registered marks. Unauthorized use is strictly prohibited.